

# COMBINE PRODUCTIVITY GUIDE



## FEATURING

- Service Inspections
- Safety
- Maintenance
- Operation
- Troubleshooting
- Updates and Kits
- AFS
- Storage
- Combine Product Support Kits



# GENERAL INFORMATION

## Introduction

For 30-years, the Case IH Axial-Flow® Combine has been the benchmark to which all other combines have been compared. And for 30-years, no other combine has measured up to the Case IH Axial-Flow.

The axial rotor concept of threshing and separating has been delivering more, top-quality grain to the tank than any other system. Gentle grain-on-grain threshing, the flexibility of multiple rotor, and concave and separator grate configurations makes the Axial-Flow at home in the corn and beans of the Midwest, sunflowers, cereal and oil grains, rice, and hard-threshing grass seed.

Since its introduction, 17 models of Axial-Flow combines have entered the market. As with any successful product line, good business dictates that if you have something good, see if you can make it better. The Axial-Flow has followed that nugget of wisdom, resulting in new productivity and quality enhancing features like the AFX rotor and the CrossFlow cleaning system. Computer technology has found its way into combines, with the integration of AFS Precision Farming and combine monitoring features; along with “smart” controls for headers, operator environment, engines, and a host of other features.

Today’s Model 2577 and 2588 Axial-Flow Combines bring more power and productivity to the field than their predecessors, with 290 and 325 horsepower engines, the muscle to work grain heads up to 36’, and 12-row corn heads in the best yielding crops and toughest conditions.

## CONTENTS

Service Inspections.....	3
Safety/Fire Prevention .....	4
Fire Prevention/Periodic Maintenance .....	5
Periodic Maintenance .....	6-7
General Maintenance .....	8-11
Operation.....	12-16
Troubleshooting.....	17-26
Updates and Kits.....	26-28
AFS.....	28-32
Storage.....	33
Combine Product Support Kits.....	34-38

## OUR COMMITMENT TO YOU

Many companies who improve their products make you buy a “new one” to take advantage of new concepts and technology. That is where Case IH differs from the crowd. We know you have to make your machinery investment stretch even more than ever. Case IH offers updates to allow you to take advantage of applicable new technology, like the AFX rotor and CrossFlow fan system, on your older

model Axial-Flow. That’s what this book is all about—helping you get more VALUE from your relationship with Case IH. Whether you are purchasing a new machine, or keeping your current machine up and running at top productivity; we trust your loyalty to Case IH, and know you will continue to trust Case IH Axial-Flow combines to get your treasured harvest out of the field and into the bin.



# SERVICE INSPECTIONS

## Take Full Advantage of its Capabilities

Have you, or did someone you know purchase a new combine in the last few years and continued to use it in much the same way as the combine it replaced? Many times operators do not fully realize and take advantage of modern features. As a result of not fully utilizing the combine's features, the owner may not be getting all the value from the money spent.

Many of the items suggested in this booklet can be completed by the owner when preparing for the season or the operator when starting a new field. Other adjustments, service procedures, or repairs might be more effectively completed by your dealer's trained service technicians.

## MAINTENANCE CHOICES, BEING PREPARED FOR DEMANDING CONDITIONS

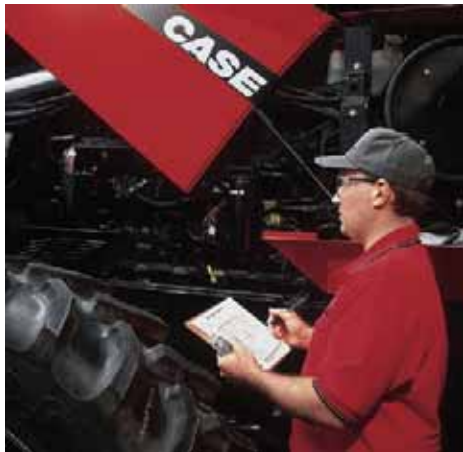

Ask your Case IH dealer about Customized Maintenance Inspections. It is a proactive way to be sure your combine will operate at its best possible performance when you need it.

Customized Maintenance Inspections include a visual and functional inspection of your combine. They can be used as a pre-season or as a post-season tune-up.

### Benefits include:

- Increased productivity
- Less downtime during the season
- Lower operating costs
- Improved fuel economy
- Documented maintenance
- Service by Case IH-trained technicians
- Service with Genuine Case IH lubricants, filters, and parts

The combined advantages of Customer Maintenance Inspection services should result in a lower cost of ownership and higher resale values.

## Documented Service Promotes High Resale Value

When you schedule your equipment for annual maintenance inspection services, your Case IH dealership places annual UPTIME Action Maintenance decals on your equipment after each inspection, distinguishing your commitment to keep your machines running in top condition. Not only does annual maintenance support your productivity in the field, each decal symbolizes completed service—which may increase the resale value of your equipment.

Because Case IH technicians use Customized Maintenance Inspection checklists for each inspection, you can rest assured the service is thorough and nothing is overlooked.



# SAFETY/FIRE PREVENTION

## Safety

Harvest is the culmination of a full year of hard work and great investment. We know harvest “windows of opportunity” are not always as wide as you would like, with weather and crop conditions having the final say on when the crop gets into the bin. Make sure you spend every available day harvesting, instead of recuperating because poor judgment resulted in an accident. Observe all Safety Instructions in the combine Operators Manual, and these specific safety rules, for a safe and profitable harvest season.

## General Safety Rules

- Be sure you re-read the Operator’s Manual to review all safety instructions
- Be sure you read and understand the safety messages on all decals on your combine
- Never start or move the combine until you are sure everyone is out of the way
- Never start the combine until the operator is familiar with all controls. This rule applies even if an experienced operator or trainer is present. Waiting until a quick decision is required to prevent an accident is not a good learning experience.
- Always put the shift lever in neutral before starting the engine
- Do not allow riders (except during training)
- Set the parking brake, turn off the engine, and remove the key before leaving the cab for cleaning, adjusting, or lubricating
- Never enter the grain tank or engine compartment when the engine is running
- Many of the combine systems are electrically actuated. Unlike mechanical linkages that have a distinct and visible outcome when shifted or adjusted, activity such as unplugging an actuator may result in unexpected component movement. This accents the need to stop the combine engine before performing any service operation.
- Always stop your combine engine when refueling. Do not smoke while refilling the fuel tank.
- Solidly block or lower the feeder cylinder safety stand before working on or under the header. Keep ladders steps, and platforms free of trash and mud accumulations.
- Always keep all guards and shields in place

- Drive at moderate speeds in the field and on the road. Keep the combine in gear when going down hill.
- Use extreme caution when removing the radiator cap to avoid contact with hot pressurized coolant. Allow the engine to cool before opening the system. If the cap must be removed while the system is hot, protect hands with a thick layer of rags to absorb spilled coolant. Do not wear gloves that can become soaked with hot fluid and will burn skin before gloves can be removed.
- Be sure everyone is clear of the area before unloading grain – flowing grain can trap an adult in 10-seconds or less
- Dress appropriately when performing service work. Do not wear loose clothing that can become entangled with the machine.
- Always engage feeder cylinder safety stand before working under feeder or header
- When transporting on the highway, double check bridge and overhead power line clearances. Remove and transport wide headers lengthwise to promote the safest possible conditions
- Take frequent breaks to maintain maximum attention
- Be alert. If you’re constantly alert, you’ll be in a better position to handle emergencies.

***Think safe ... Work safe ... Be safe.***

## Fire Prevention

Few things could ruin an otherwise rewarding harvest more than a devastating combine fire. Spending some time each day keeping the combine clean and well-maintained is the best way to preserve harvest as a good memory, instead of something you would rather forget.

By nature, mature crops are dry and dirty, and are sources of considerable debris that can accumulate on harvesting equipment. During busy harvest-time, operators may not like taking the time to clean the combine daily. ***The most appropriate cleaning time is at the end of the day. Any debris that may be near a hot surface, or is possibly already a smoldering pile, is removed before it becomes a problem.***

- Attempts to perform only major, time-consuming cleanings on a less-frequent basis will likely require ***MORE TIME*** in the course of the harvest season, than to make a proactive commitment to devote a few minutes to cleaning on a daily basis. Cleaning time is also a good time to perform a basic visual machine inspection.

# FIRE PREVENTION/PERIODIC MAINTENANCE

## Fire Prevention (cont.)

Some additional “food for thought.” Modern, high-productivity combines are powerful machines, and along with power comes heat. Fire cannot start without heat and fuel. You cannot remove the heat from the engine, hydraulics and other hard-working systems, but you can remove the fuel source by keeping your combine clean.

Areas requiring special attention to keep combustible debris away from high heat are:

- The engine, specifically the exhaust manifold, turbocharger, muffler, and exhaust pipe
- Hydrostatic pump, motor, hydraulic lines, and tubes
- Brake and transmission housings
- Electrical components
- Engine drives and all moving parts
- Batteries and battery cables
- Straw spreader drive gear compartments

Equip your combine with at least two fire extinguishers. Refer to Operator’s Manual for suggested locations.

- It’s a good idea to have at least one water-charged extinguisher on your combine. However, use a water extinguisher only on crop debris. Water applied to an oil fire may tend to spread the flames.
- Watch for fuel or hydraulic fluid leaks. Correct any fuel or hydraulic fluid leak immediately. Clean the machine thoroughly after any hydraulic fluid or fuel leaks or spills. Residual hydraulic fluid or fuel mixed with trash creates a very combustible mixture. This can make an accidental machine fire much harder to control.

## Periodic Maintenance

During harvest time, it is easy to get in a hurry and perhaps neglect one or two “minor” maintenance items. Before long, more items may start to seem “minor”, in an effort to get to the field a few minutes sooner. Then, a breakdown may be a reminder that no maintenance item is “minor”. Not only will the repair be more costly than maintenance, it will be much more time-consuming. ***Be sure to follow all the maintenance recommendations in your Operators Manual, and enhance your combine productivity all season long.***

Complete daily maintenance steps are detailed in the combine Operator’s Manual. Some checks should be made at the end of each day’s use, preferably while performing daily cleaning:

- Check all drive chain and belt tension
- Check the feeder chain
- Empty the rock trap
- Open the cooling system rotary screen and cooler elements to check for debris accumulation and restricted air flow
- Rotate the rotary screen to assure screen sections are not damaged, out of place, or missing
- Grease the rotor drive. (Use only Case IH 251HEP grease or equivalent pure lithium grease. **DO NOT** use moly or graphite based grease that can dry and “cake” in the high temperature rotor drive application, reducing lubricating effectiveness)
- Grease the tailings return auger bearings
- Grease unloader pivot
- Confirm adequate tire inflation

Additional checks are recommended to be performed prior to starting, when the engine is cooled to ambient temperature.

- Check the engine oil level
- Check coolant recovery tank level sight glass
- Check hydraulic reservoir level sight glass
- Drain water from the primary fuel filter water separator
- Confirm audible alarms and indicator lamps function properly on startup

Less frequent (weekly, 50 hr.), but regular maintenance should include:

- Use compressed air to clean debris from the alternator
- Inspect or clean the engine air filter housing and element
- Re-lubricate drive chains if previously lubricated

# PERIODIC MAINTENANCE



# PERIODIC MAINTENANCE

## 10 Hour (Daily) Maintenance Checks

Checks and lubrication best performed on shutdown, along with combine cleaning:

- 1 Check all drive chain and belt tension
- 2 Check the feeder chain
- 3 Empty the rock trap
- 4 Re-lubricate feeder reverse chain
- 5 Check for debris accumulation and restricted air flows in the radiator and cooling elements
- 6 Inspect the rotary screen for damaged or missing screen segments
- 7 Grease the rotor drive cam drive bearings
- 8 Grease rotor driven pulley
- 9 Grease the tailings delivery auger bearings
- 10 Grease chaffer hangers (both sides)
- 11 Grease unloading tube pivot
- 12 Re-lubricate unloader drive and auger chains
- 13 Re-lubricate tailings elevator drive chain
- 14 Re-lubricate grain elevator drive chain
- 15 Confirm adequate tire inflation

Additional checks are recommended to be performed prior to starting, when the engine is cooled to ambient temperature.

- 16 Check the engine oil level
- 17 Check air filter restriction indicator
- 18 Clean alternator screen
- 19 Check coolant recovery tank level sight glass
- 20 Check hydraulic reservoir level sight glass
- 21 Drain water from the primary fuel filter water separator
- 22 Confirm audible alarms and indicator lamps function properly on startup

## 50 Hour (Weekly) Maintenance Checks

- 23 Use compressed air to clean the alternator
- 24 Inspect or clean the engine air filter canister and element
- 25 Grease auxiliary pump tensioner arm
- 26 Grease rotor drive pulley
- 27 Grease rotor speed control (front and rear)
- 28 Unloader drive tightener arm
- 29 Grease straw chopper idler arm
- 30 Grease cleaning fan pulley
- 31 Grease straw spreader idler arm
- 32 Grease cleaning fan belt idler arm
- 33 Grease fan driven pulley
- 34 Grease feeder engage idler arm
- 35 Grease fan drive belt tightener arm
- 36 Grease steering Axle front and rear pivots
- 37 Grease left and right tie rod ends
- 38 Grease right and left steering cylinder ball joints
- 39 Grease right and left steering knuckles (upper and lower)

**Check Operator's Manual for additional items at every-other 50 hour (100 hour) interval**

# GENERAL MAINTENANCE

## Additional Service Recommendations (Daily Maintenance)

**Engine Air Filter:** Replacing plugged filters is the recommended method to assure optimum engine protection.

- If the filter is cleaned, use extreme care directing low pressure air from the inside to dislodge dirt. Do not strike the inside of the element with the air wand to avoid damage.
- **NEVER tap or pound the element on a hard surface to dislodge dirt, as damage is likely to occur**
- Check the filter element with a light inside the element after cleaning to assure the element paper and the connection of the pleats to the element end plates has not been damaged

**If frequent Air Filter service is required:** Strato-tubes in the air filter canister may be plugged, diminishing the effect of the dust aspirator (see figure 8.1). The result is unnecessary contamination reaches the filter element and must be trapped in the paper filter media. This results in shortened service interval, and additional service requirement. Contact your Case IH dealer for service to the air filter strato-tube assembly (see figure 8.2).

## Engine Oil and Filter

When 2300 series combines are shipped from the factory, the crankcase is filled with SAE 15W40 engine oil.

- **SAE 10W30 is not recommended, even in cold weather if ambient temperatures may exceed 50° F**
- Always use a top-quality engine oil. Case IH No. 1™ engine oil has been specifically formulated for heavy-duty, high-temperature operation in diesel engines (see figure 8.3).
- The oil change interval is 300 hrs. for 2006 and later combines, 250 hrs. or less for pre-2006 models when using Case IH oil and filters. Adhere to engine oil change intervals published in the combine Operator's Manual.
- Intervals are not established for non-Case IH oil and filters. Oil change frequency should be increased significantly when other brand oil and filters are used.

## Hydraulic System

The hydraulic system works hard propelling, lifting, turning, and controlling functions on your combine (see figure 9.1).

- Use only the finest hydraulic fluid, namely Case IH Hy-Tran® Ultra hydraulic transmission fluid ... the only brand guaranteed to deliver complete protection. Don't take a chance on ordinary lubricants

- Replace the hydraulic filter as specified in the Operator's Manual
- Wipe dust and dirt from the header hydraulic hose connection block before disconnection and connection of the head to reduce dirt entry into the hydraulic system



Figure 8.1



Figure 8.2



Figure 8.3



# GENERAL MAINTENANCE

## Hydraulic System (cont.) “What’s with the Color of the Oil in My New Combine?”

The Hy-Tran fluid and the engine oil shipped in new combines is dyed to allow easier detection of leaks.

Replacement oils are not dyed. Follow recommended change intervals for the original fluids, and do not replace fluid because it is the “wrong color”.

## Roller Chain

Drive chains work hard on a combine, and proper maintenance is crucial for reliable operation. Most important, consult the Operator’s Manual for tension adjustments and specifications (see figure 9.2).

- Insufficient tension allows chains to whip during operation, placing shock loads on the chain, sprockets, shafts, and bearings
- Loose chains do not transmit power at a consistent speed, and in extreme cases can slip or jump off sprockets
- Excessive tension places added load on the chains, sprockets, and associated parts
- Chain alignment is critical. Make sure chain is properly aligned, especially after performing repairs.
- Unless specified, operator choice determines if chains are lubricated, or run dry. If chains are initially lubricated, re-lubricate regularly to flush contaminants from the chain and maintain lubricant protection.
- Use chain lubricant formulated to cling to the chains, providing longer lasting protection with less oil spray onto the machine

## Belts

The same basic standards apply to belts, as chains. Follow specified tension adjustments to promote long belt life and efficient operation (see figure 9.3).

- Avoid overstressing components with excessive tension
- Inadequate tension allows belts to slip, accelerating wear and adversely affecting performance
- Belt alignment and tension not properly maintained may result in slippage, uneven wear, and poor tracking
- Alignment is particularly important with multi-vee and poly-vee belts. Uneven loading will affect belt life and efficiency if improperly aligned.

## Bearings

Be sure to keep weeds and crop residue from wrapping on shafts near bearings.

- If the material starts to create a drag on the seal it could damage the seal and allow moisture and debris to enter the bearing, and lubrication to escape. The seal failure will ultimately lead to a bearing failure.
- Always follow the lubrication schedules in the Operator’s Manual. Over-greasing will also damage seals, and shorten bearing life.



Figure 9.1



Figure 9.2



Figure 9.3

# GENERAL MAINTENANCE

## AFX Rotor Impeller Blade Wear

The AFX rotor impeller can wear significantly before adverse feeding performance is observed. As the impeller wears, the distance between the impeller and transition cone does not vary greatly, and has little effect on crop flow.

- Wear may be somewhat uneven, especially in small grains. This is normal, and should not be cause for replacement (see figure 10.1).
- Wear that develops a noticeable “hook” ① may lead to hair-pinning of material, and impaired flow. Impeller replacement is necessary in this case (see figure 10.2).
- Replacement is indicated when wear progresses into mounting bolt holes, or feeding is noticeably affected. Your Case IH dealer can refer to Service Bulletin NHE SB 029 05 for the correct method to measure impeller wear to determine if replacement is suggested (see figure 10.3).

## Anti-Freeze/Coolant Maintenance

The duty-cycle of engines in today’s combines operate at near full-load conditions a high percentage of the time. The cooling system must rid the engine of significant heat in these conditions. Proper maintenance is necessary to keep the system working at top efficiency and protecting internal engine components.

- Check coolant level at the de-aeration tank sight glass daily to assure the coolant level is adequate (see figure 10.4). If coolant must be added, observe Operator’s Manual safety requirements prior to removing the radiator cap.
- Open the rotary screen and assure debris is not accumulated on radiator fins, restricting air flow (see figure 10.5)
- Use only low silicate, heavy-duty coolant formulated for diesel engines. Mix with clean water in a 50/50 ratio. Do not use automotive grade coolant available from common retail outlets. It is not low silicate, and is inadequate for heavy-duty use.
- Replace the coolant conditioning filter every 250 hrs.
- Replace the coolant and coolant filter every two years. Refer to the Operator’s Manual.

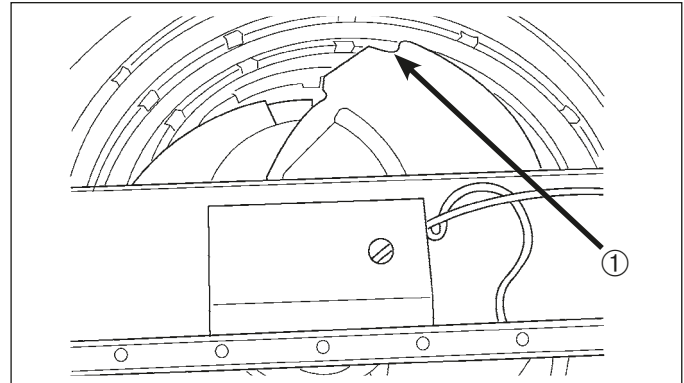

Figure 10.2

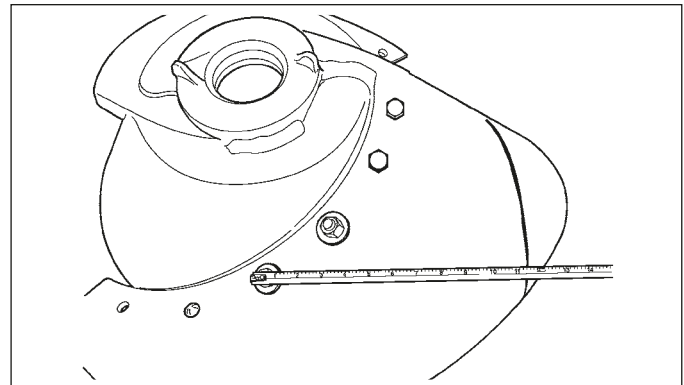

Figure 10.3



Figure 10.4



Figure 10.5

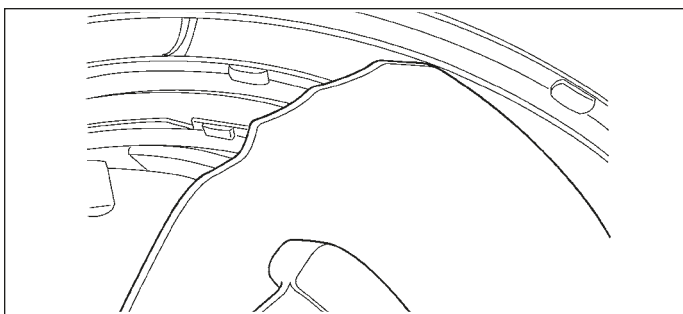

Figure 10.1

# GENERAL MAINTENANCE

## Air Intake Rotary Screen

Rotate the rotary screen to assure screen sections are not damaged, out of place, or missing (*see figure 11.1*). Also check screen rollers for freedom of movement, brush condition, and the external rubber seal condition. Lift the rubber seal and inspect the yellow wear strip for deterioration or excessive wear while rotating screen (*see figure 11.2*).

## Air Conditioning

Operators must be sure not to cover the cab air conditioner re-circulation filter behind the seat. The area can become a “catch-all” and the filter becomes covered up with jackets, lunches, paper towels, etc. Keep the area clean for best air quality conditions.

## Bio-diesel Fuel

The use of bio-diesel fuel is on the rise. A bio-fuel blend, up to a maximum of 5% (B5) has been approved for use in Case IH diesel engines. While bio-diesel has distinct advantages such as its clean burning characteristics, users of bio-diesel should be aware of some specific conditions.

- Bio-diesel blends attract more moisture, and may require more frequent water separator draining
- Bio-diesel should not be left in engines that are stored more than four months
- A lower cloud point may contribute to harder cold-weather starting, making bio-diesel less attractive than conventional diesel fuel for winter use
- Depending on fuel quality, more frequent filter changes may be required

In addition to low-emissions, some other bio-diesel advantages include:

- Bio-diesel mixes well with conventional diesel fuel
- Oil change intervals remain unchanged are not affected with bio-diesel use

As with all other fuels, purchase high quality bio-diesel fuel from known reputable suppliers to assure trouble-free combine operation.

## Wheel Bolt Torque

Wheel bolt torque must be checked when new and periodically thereafter. Refer to the Operator’s Manual for correct torque for your combine. An accurate torque wrench is necessary to confirm correct tightening values.

## Welding on Combines

Microcomputers and solid state electrical components have become a way of life, and today’s combines are no exception. This makes it essential that special precautions be taken prior to welding ANYWHERE on the combine. Solid state components have little tolerance for errant voltage. The high current flow during the welding process can damage sensitive controllers and components on the combine, with disastrous consequences.



Figure 11.1



Figure 11.2

- Disconnect ALL battery cables prior to welding. This includes positive AND negative cables. (The electrical system uses two 12-volt batteries connected in parallel. This means that both positive cables connect to the electrical system, and both negative cables connect to ground.)
- Follow Operator’s Manual safety instructions for cable removal, disconnecting negative cables first, and re-connecting negative cables last

## Corn Head Stalk Roll Bearing Maintenance (Older Corn Heads prior to 1993)

Corn heads built since 1992 have sealed front stalk roll bearings. Older heads required consistent maintenance and correct adjustment to achieve the best possible bearing life.

1. Grease the stalk rolls with Case IH 251H EP grease every four operating hours.
2. Add grease until excess flows from the bearings to flush dirt and debris from bearings.
3. Adjust the height of the divider points to provide clearance between the roll points and the ground. Avoid running the head extremely low and allowing the rolls to contact the soil surface.
4. Thoroughly grease the bearings before storing the corn head.

# OPERATION

## Draper Headers

As combine capacity has increased in recent years, a challenge facing designers and operators was how to satisfy the appetite of these machines with a grain platform. Sure, heads could be made wider, but then they really need to “bend” to follow variations in ground contour. The answer has been the return of the draper (see figure 12.1).

- In addition, drapers offer exceptionally gentle, smooth crop flow to the feeder, and efficient “heads-first” feeding into the rotor. This all adds up to 20% more capacity and productivity (see figure 12.2).
- Case IH offers rigid drapers for applications (such as rice) where the head will not be run on the ground, and flex-drapers (for small grains and soybeans) where the head frequently is operated at to near ground level.
- Flex-drapers are made up of three independently floating header sections that allow 13" of vertical float at the ends of the header, and 4.8 degrees of lateral float (12" at the end of a 30' header)
- Split two-section reel follows header flex to maintain consistent reel-to-knife adjustment for best crop feeding
- The header suspension allows complete adjustment. Refer to specific adjustments found in the Operator’s Manual Tests can be performed to confirm flotation settings prior to entering the field.
- Cutter Bar Straightness
- Float (vertical) setting
- Wing Balance (smile/frown, right/left wing)
- Float Optimizer

During operation, the operator can make control adjustments:

- Float optimizer (controls ground pressure using automatic height control)
- Hydraulic Guard Angle (controls stubble height and clearance over rocks and ground trash)
- Combine Auto Header Height Setting (Float Optimizer)
- Decrease ground pressure if skid shoes are riding heavy, pushing trash
- Increase ground pressure if header is riding up on stubble
- Optimizer gauge indicates the amount of ground pressure

**For optimum performance, reel and draper adjustments are critical:**

- Reel position and speed should be set so the reel lightly flicks the crop onto the drapers, while not impeding crop flow across the header. This typically works out to a reel speed about 10% faster than ground speed.
- Draper speed is not dependent on ground speed. Draper speed should be set for a consistent windrow formation entering the combine. Increased draper speed does not equal increased capacity (see figure 12.3).



Figure 12.1



Figure 12.2



Figure 12.3

## Rock Trap

The mechanical rock trap on the 2300 Series combines is mounted at the top of the feeder housing, directly in front of the rotor. The rock trap uses a three-blade beater to direct stones from the crop flow from the feeder to the rotor downward into the rock trap (see figure 13.1). The rock trap will fill with grain and crop material during normal use, however the force of rocks expelled from the beater will push rocks into the trap.

The rock trap must be emptied daily, more often if harvesting in rocky conditions.

The balance between optimum rock protection performance and feeder capacity is determined by the beater speed and beater blade extension adjustments.

- Rock trap performance is greatest with faster beater speed, and beater extensions adjusted to the fully extended position (see figure 13.2)
- Excessive beater speed and blade extension will restrict crop flow

The beater blades passing rapidly past the feeder form a “wall” that inhibits the flow of material past the beater, and on to the rotor.

- Beater blade extensions are mounted with slotted holes. Retracting extensions will allow the greatest material flow, however rock protection will be reduced.
- Sprockets on the left side of the feeder are used to adjust beater speed. Sprocket combinations are 40 tooth drive (on feeder shaft) and 20 tooth driven (on beater shaft) for the fastest beater speed (see figure 13.3).
- A 30 tooth driven sprocket, and three additional chain links, are supplied with the combine to allow a slower beater speed when used with the 40 tooth drive sprocket.

Depending on feeding conditions and the number of rocks that could potentially be picked up while harvesting, operators need to make adjustments to speed and blade extension to protect the combine with minimal impact on feeding performance.

- In tough feeding conditions or material wrapping, such as a high degree of green stems, serrated blade extensions can be ordered and installed on the beater to improve feeding aggressiveness
- Lower beater speeds will also reduce the incidence of wrapping

The feeder drum with stone retarder should be allowed to float on combines equipped with a rock trap.

- The stone retarder drum is intended to stop the feeder if rocks are encountered that are too large for the rock trap (see figure 13.4)
- Smaller rocks should be allowed to enter the feeder, and are caught in the rock trap
- Setting stops to hold the drum in the down position will impair feeding performance

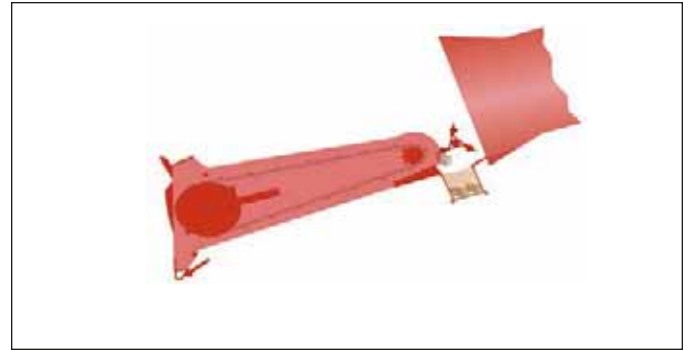

Figure 13.1

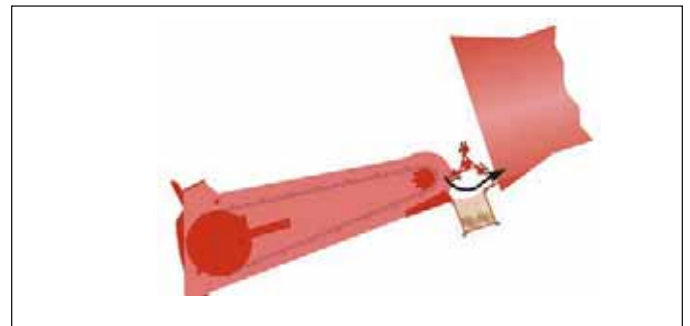

Figure 13.2



Figure 13.3

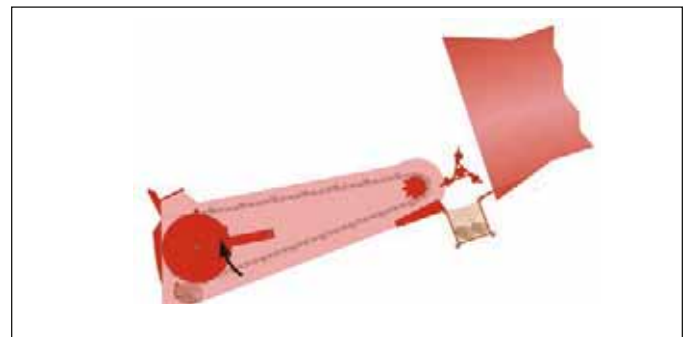

Figure 13.4

# OPERATION

## Initial Settings for Rotors

Every experienced operator knows crop and harvesting conditions vary from season-to-season, and field-to-field. Taking advantage of years of experience, the following tables have been assembled as recommendations for initial settings as harvest begins, in average harvesting conditions. Fine-tuning as harvest progresses will allow you and your combine to maximize performance.

### STANDARD ROTOR

Crop	Rotor Speed		Concave Setting		Grate	Cleaning System Type											
	Type		Indicator Setting	Type		Short (1620, 1640, 1660, 1680)				Long (1644, 1666, 2144, 2166, 2344, 2366)				Long (1680, 1688, 2188, 2388)			
	1640 1644 1660 1666	1680 1688				Chaffer Setting	Shoe Setting	Fan RPM Paddle Blade	Fan RPM Cross Flow	Chaffer Setting Frt.-Mid.-Rear	Shoe Setting	Fan RPM Cross Flow	Chaffer Setting Frt.-Mid.-Rear (3 lever)	Shoe Setting	Fan RPM Paddle Blade	Fan RPM Cross Flow	
<b>Barley</b>	750	850	2	SW1, LW 2 & 3	1 Slot/2 Bar	1/2	1/4	750	1000	1/2-1/2-5/8	3/8	1000	1/2-1/2-5/8	3/8	1000	1000	
<b>Corn</b>	500	500	Corn	LW	Bar ①	1/2	9/16	1000	1100	1/2-1/2-5/8	1/2	1100	1/2-1/2-5/8	1/2	1100	1100	
<b>Milo/ Maize</b>	720	600	3	LW	Bar	1/2	3/8	900	1100	3/8-1/2-1/2	5/16	1100	3/8-1/2-1/2	5/16	1100	1100	
<b>Rye Grass</b>	900	750	4 or 5	SW	Slotted	1/2	1/4	450	450 ⑤	3/8-1/2-1/2	1/4	450 ⑤	3/8-1/2-1/2	1/4	450 ⑤	450 ⑤	
<b>Soybeans</b>	600 ②	500 ②	4	LW	Bar/ Slot	5/8	3/8	1000	1100	1/2-5/8-5/8	3/8	1050	1/2-5/8-5/8	3/8	1100	1100	
<b>Sunflower</b>	420	350	5	SW1, LW2, & 3	Slot/ Solid ③	5/8	7/16	700	770	3/8-1/2-5/8	7/16	770	3/8-1/2-5/8	7/16	770	770	
<b>Wheat</b>	1080	900	2	SW	Slotted	5/8	3/8	850	1050	3/8-1/2-5/8	1/4	1050	3/8-1/2-5/8	1/4	1050	1050	

Table 14.1

① With notched separator bars.  
 ② Some soybean varieties may require rotor speeds up to 700 RPM or more.  
 ③ 1st Slotted, 2nd and 3rd solid.  
 ④ Helical kickers to enhance material flow; two suggested for 1680; three additional suggested for 1660, 1666, 2144, and 2166.  
 ⑤ Air volume may be regulated while harvesting light grasses by rotating the fan cut-off plate to a vertical position.  
 ⑥ Do not open front of chaff sieve more than center section.

## SPECIALTY/AFX ROTOR

Crop	Rotor Speed		Concave Setting		Grate	Cleaning System Type											
						Short (1620, 1640, 1660, 1680)				Long (1644, 1666, 2144, 2166, 2344, 2366)				Long (1680, 1688, 2188, 2388)			
						Chaffer Setting	Shoe Setting	Fan RPM Paddle Blade	Fan RPM Cross Flow	Chaffer Setting Frt.-Mid.-Rear	Shoe Setting	Fan RPM Cross Flow	Fan RPM Cross Flow	Chaffer Setting Frt.-Mid.-Rear (three lever)	Shoe Setting	Fan RPM Paddle Blade	Fan RPM Cross Flow
<b>Barley</b>	1620 750	1640 1660 1680 1688 1666 800	Indicator Setting 2	Type SW	Slotted	1/2	1/4	750	1000	1/2-1/2-5/8	3/8	1000	1000	1000			
<b>Corn</b>	450	400	3-5	LW	Bar	1/2	3/8	1000	1100	1/2-1/2-5/8	3/8	1100	1100	1100			
<b>Edible Bean</b>	550	600	3-5	LW/ Slotted 2388	Bar	5/8	1/2	900	1050	1/2-1/2-1/2	3/8	1050	1100	1100			
<b>Grass</b>	650	600	2-4		Slot/ Solid ②	3/8	1/4	400	450 ④	1/4-3/8-3/8	1/4	450 ④	450 ④	450 ④			
<b>Milo/ Maize</b>	700	600	3	LW	Bar	1/2	3/8	900	1100	3/8-1/2-1/2	5/16	1100	1050	1050			
<b>Rice</b>	1050	850	2	LW	Bar	1/2	5/16	750	800	3/8-3/8-1/2	5/16	880	880	880			
<b>Soybeans</b>	700 ①	700 ①	3-4	LW	Bar	5/8	3/8	1000	1100	1/2-5/8-5/8	3/8	1050	1100	1100			
<b>Sunflower</b>	420	350	5	LW Slotted 2388	Slot/ Solid ② ③	5/8	7/16	700	770	3/8-1/2-5/8	7/16	770	770	770			
<b>Wheat</b>	1050	1000	2	SW	Slotted	1/2	1/4	850	1050	1/2-1/2-5/8	1/4	1050	1050	1050			

Table 15.1

① Some soybean varieties may require rotor speeds up to 700 RPM or more.  
 ② 1st Slotted, 2nd and 3rd solid.  
 ③ Helical kickers to enhance material flow: two additional suggested for 1660, 1666, 2144, and 2166.  
 ④ Air volume may be regulated while harvesting light grasses by rotating the fan cut-off plate to a vertical position (Cross Flow Fan).  
 ⑤ Do not open front of chaff sieve more than center section.

# OPERATION

## Specialty Rotor, AFX Rotor - Initial Crop Settings 1688/2188, 2377/2388 and Upgrades of Other Models

Crop	Rotor		Concave		Chaffer Setting (Inch) ⑦			Shoe Setting (Inch)	Fan Speed	Grate Type	Transport Vane Position
	Speed	Gear Range	Indicator	Type ④	Front	Middle	Rear				
Alfalfa	650	Middle	1	SW	1/4	3/8	3/8	Round Hole	500	Slot	Middle
Barley	700	High	2	SW	1/2	1/2	5/8	3/8	1000	Slot	Middle
Lentil Beans	300	Low	2	LW/SL	1/2	1/2	5/8	1/8	550	Slot	Fast
Pinto Beans	300	Low	3	LS/SL	1/2	1/2	1/2	3/8	850	Slot	Fast
Sunflower ⑧	300	Low	5	LW	3/8	1/2	5/8	5/16	770	Bar	Fast
Bentgrass ⑤	900	High	0	SW	1/4	3/8	3/8	1/16	450	Slot	Middle
Bluegrass ⑤	400	Low	1-1/2	SW	3/8	1/2	1/2	1/16	500	Slot	Middle
Brome ⑤ ⑧	500	Middle	3	SW	5/8	3/4	3/4	5/16	650	Slot	Fast
Rye ⑤	650	Middle	4-5	SW	3/8	1/2	1/2	1/4	450	Slot	Fast
White Clover ⑤	900	High	0	SW	3/8	1/2	1/2	1/16	500	Slot	Middle
Corn	400-500	Middle	3-5	LW	1/2	1/2	5/8	3/8	1100	Bar	Rear
Corn (w/straight separator bars) ① ②	300-450	Low-Middle	3-5	LW	1/2	1/2	5/8	9/16	1000	Bar	Rear
Edible Beans (Navy, Pinto)	300-400	Low	3-5	LW/SL	1/2	1/2	1/2	3/8	900	Bar	Middle
Flax	850	High	1	SW	1/4	1/4	1/2	1/8	500	Slot	Middle
Maize/Milo	450	Middle	3	LW	3/8	1/2	1/2	5/16	1100	Bar	Middle
Mustard	300	Low	4	SW	1/2	1/2	1/2	1/16	800	Slot	Fast
Oats	600	Middle	3	LW	1/2	1/2	5/8	3/8	780	Slot	Middle
Peas - Black	300	Low	2	LW/SL	1/2	1/2	1/2	3/8	700	Bar	Fast
Rape	400	Low	4	SW	1/4	3/8	1/2	1/16	600	Slot	Fast
Rice ③ ②	850	High	2	LW	3/8	3/8	1/2	5/16	880	Bar	Middle
Wild Rice	600	Middle	1	LW	1/2	1/2	1/2	9/16	850	Bar	Middle
Safflower ⑧	300	Low	4	LW	3/8	1/2	5/8	5/16	800	Bar	Fast
Soybeans ⑥	350-650	Low Middle	3-4	LW	1/2	5/8	5/8	3/8	1050	Bar	Middle
Wheat ①	1050	High	2	SW	1/4	1/2	1/2	1/4	1050	Slot	Middle
Grass ⑤ ⑧	550	Middle	2-4	SW	1/4	3/8	3/8	1/4	450	Slot/Solid	Middle

Table 16.1

- ① Straight separator bars may be needed for harvesting corn yielding more than 150 bushels per acre (9400 kg/ha) and in other crops during dry conditions. Increase fan speed to 1250 RPM in wet corn.
- ② Once installed, straight separator bars need to be removed only for harvesting rice, edible beans, and similar viney crops.
- ③ Tough rice requires the use of spiked rasp bars over the concave area and the grate area. Set concave indicators at Number 4 when spiked rasp bars are used in the concave area.
- ④ LW - Large Wire (1/4" Diameter); SW - Small Wire (3/16" Diameter); SL - Smooth Slotted.
- ⑤ Use of non-spiked rasp bars in all positions is recommended for most grass seed harvest conditions. Spiked bars may be helpful in extremely damp crops. Rotate fan cutoff rearward to the vertical position to reduce air volume.
- ⑥ Some soybeans may require rotor speeds up to 700 RPM or more.
- ⑦ The front several inches of the chaffer sieve are, by design, set slightly more closed than the rest of the front section.
- ⑧ Slotted concave use may be beneficial to reduce damage to threshed material.
- ⑨ A common mis-adjustment is setting rotor speed too low. High moisture crops will require higher rotor speeds. The AFX Rotor may require an additional 50 to 100 RPM Rotor Speed and a slightly tighter concave in some.



# TROUBLESHOOTING

## Combine Performance Troubleshooting Tables

The following separator adjustment tables are developed for specific crops. Identify the performance issue requiring attention in the left column. The numbers indicate the suggested sequence in which adjustments should be performed. Adjustments are described at the top of the corresponding column. Complete only those adjustments with corresponding numbers. A symbol or letter appearing below a number indicates the type of adjustment action to be performed, as described in the key with each table.

### Barley

HARVEST CONDITION	ADJUSTMENT									
	Inspect Concave for Plugging	Adjust Rotor Speed	Adjust Concave	Adjust Cage Vanes	Concave Wires	Adjust Fan Speed	Adjust Chaffer	Adjust Shoe	Grate Channels	Travel Speed
<b>CLEAN GRAIN SAMPLE</b>										
Damaged Grain	2	3				4	1			
Excessive Stems / Trash	4				2	3	1	5		
<b>ROTOR LOSSES</b>	1		2				3			
Unthreshed Heads		2	1							
<b>EXCESSIVE POWER CONSUMPTION</b>	1									
GRAIN LOSS OVER CHAFFER					2	1	3			
<b>GRAIN BLOWING OVER CHAFFER</b>					1	2				
<b>SHOE SIEVE OVERLOADING</b>					3	2	1			

**KEY**  
 O = Open  
 C = Close  
 A = Add  
 R = Remove/Rearward  
 F = Forward  
 CS = Cover Slot  
 ▲ = Increase  
 ▼ = Decrease

\*Increase fan speed when sample caught at end of chaffer.  
 Decrease fan speed when sample caught 2 to 3 feet from end of chaffer.

### Corn/Popcorn

HARVEST CONDITION	ADJUSTMENT									
	Inspect Concave for Plugging	Adjust Rotor Speed	Adjust Concave	Adjust Cage Vanes	Concave Wires	Adjust Fan Speed	Adjust Chaffer	Adjust Shoe	Grate Channels	Travel Speed
<b>CLEAN CORN SAMPLE</b>										
Damaged Corn in Sample	1	2	4		3					
Fines in Sample		1	2			3	4			
Small Bits of Cob in Sample		2	5		4	3	1			
<b>ROTOR LOSSES</b>	1	2	3	4	5					
Kernels Left on Cob		1	2							
Excessive Cob Breakage		1	2							
<b>EXCESSIVE POWER CONSUMPTION</b>		1	2	3					4	
<b>CORN LOSS OVER CHAFFER</b>		3				1	2			4
<b>SHOE SIEVE OVERLOADING</b>		4				3	1	2		5

**KEY**  
 O = Open  
 C = Close  
 A = Add  
 R = Remove/Rearward  
 F = Forward  
 ▲ = Increase  
 ▼ = Decrease

# TROUBLESHOOTING

## Edible Beans

HARVEST CONDITION	ADJUSTMENT									
	Inspect Concave for Plugging	Adjust Rotor Speed	Adjust Concave	Adjust Cage Vanes	Concave Wires	Adjust Fan Speed	Adjust Chaffer	Adjust Shoe	Grate Channels	Travel Speed
<b>CLEAN GRAIN SAMPLE</b>										
Damaged Grain	6	2 ▼	3 O	5 FP		4 C	1 O			
Excessive Stems / Trash		4 ▼			2 ▲	3 C	1 C	5 CS		
<b>ROTOR LOSSES</b>	1					2 O	3 OS*			
Unthreshed Heads		2 ▲	1 C							
<b>EXCESSIVE POWER CONSUMPTION</b>		1 ▲	2 FP							
<b>GRAIN LOSS OVER CHAFFER</b>			3 O		1 ▲	2 O	4 CS			
<b>GRAIN BLOWING OVER CHAFFER</b>					1 ▼	2 O				
<b>SHOE SIEVE OVERLOADING</b>					3 ▲	2 C	1 O			

**KEY**  
 O = Open  
 C = Close  
 A = Add  
 R = Remove/Rearward  
 F = Forward  
 FP = Fast Position  
 OS = Open Slot  
 CS = Cover Slot  
 ▲ = Increase  
 ▼ = Decrease

\* Use one or more bar stock grates.

## Maize/Milo

HARVEST CONDITION	ADJUSTMENT									
	Inspect Concave for Plugging	Adjust Rotor Speed	Adjust Concave	Adjust Cage Vanes	Concave Wires	Adjust Fan Speed	Adjust Chaffer	Adjust Shoe	Grate Channels	Travel Speed
<b>CLEAN GRAIN SAMPLE</b>										
Damaged Grain	1	2 ▼					3 O			
Heavy Stems		3 ▼				2 C	1 C			
Fines / Trash		2 ▼	3 O		1 ▲					
<b>ROTOR LOSSES</b>	1	4 s	2 C	5 R			3 O			
Unthreshed Heads		2 s	1 C							
<b>EXCESSIVE POWER CONSUMPTION</b>		1 ▲							2	
<b>GRAIN LOSS OVER CHAFFER</b>		3 ▼			1 ▲	2 O			4	
<b>GRAIN BLOWING OVER CHAFFER</b>					1 ▼	2 O				
<b>SHOE SIEVE OVERLOADING</b>		4 ▼			3 ▲	1 C	2 O		5	

**KEY**  
 O = Open  
 C = Close  
 A = Add  
 R = Remove/Rearward  
 F = Forward  
 ▲ = Increase  
 ▼ = Decrease

# TROUBLESHOOTING

## Rice

HARVEST CONDITION	ADJUSTMENT									
	Inspect Concave for Plugging	Adjust Rotor Speed	Adjust Concave	Adjust Cage Vanes	Concave Wires	Adjust Fan Speed	Adjust Chaffer	Adjust Shoe	Grate Channels	Travel Speed
<b>CLEAN GRAIN SAMPLE</b>										
Damaged Grain / Hulling	3	1 ▼	4 O		5 R		2 O			
<b>ROTOR LOSSES</b>	1	2 ▼	3 C							
<b>POOR MATERIAL FLOW</b>		1 ▲	2 C	3 M	4 R					
<b>UNTHRESHED HEADS</b>		1 ▲	2 O				3 C			
<b>EXCESSIVE POWER CONSUMPTION</b>		1 ▲	2 O							3
<b>GRAIN LOSS OVER CHAFFER</b>		3 ▼			1 ▲	2 O				4
<b>GRAIN BLOWING OVER CHAFFER</b>					1 ▼	2 O				3
<b>SHOE SIEVE OVERLOADING</b>		4 ▼			3 ▲	1 C	2 O			

**KEY**  
 O = Open  
 C = Close  
 A = Add  
 R = Remove/Rearward  
 F = Forward  
 M = Middle  
 ▲ = Increase  
 ▼ = Decrease

## Rye Grass

HARVEST CONDITION	ADJUSTMENT									
	Inspect Concave for Plugging	Adjust Rotor Speed	Adjust Concave	Adjust Cage Vanes	Concave Wires	Adjust Fan Speed	Adjust Chaffer	Adjust Shoe	Grate Channels	Travel Speed
<b>CLEAN GRAIN SAMPLE</b>										
Heavy Stems		4 ▼	5 O		3 ▲	2 C	1 C			
Unthreshed Heads		1 ▲	2 C				3 C			
Excessive Stems / Trash		4 ▼	5 O		1 ▲	3 C	2 C			
<b>ROTOR LOSSES</b>	1	2 ▼	3 C							4 ▼
<b>EXCESSIVE POWER CONSUMPTION</b>		1 ▲	2 O							3
<b>GRAIN LOSS OVER CHAFFER</b>					1 ▼	2 O				3
<b>GRAIN BLOWING OVER CHAFFER</b>		3 ▼			1 ▲	2 O		4 ▲	5	
<b>SHOE SIEVE OVERLOADING</b>		4 ▼			3 ▲	1 C	2 O		5	6*

**KEY**  
 O = Open  
 C = Close  
 A = Add  
 R = Remove/Rearward  
 F = Forward  
 ▲ = Increase  
 ▼ = Decrease

\*Change the concave configuration to more small wire concaves.  
 Note: Install shoe bottom pan.

# TROUBLESHOOTING

## Soybean

HARVEST CONDITION	ADJUSTMENT									
	Inspect Concave for Plugging	Adjust Rotor Speed	Adjust Concave	Adjust Cage Vanes	Concave Wires	Adjust Fan Speed	Adjust Chaffer	Adjust Shoe	Grate Channels	Travel Speed
<b>CLEAN BEAN SAMPLE</b>										
Damaged Grain	3	1 ▼	4 O		5 R			2 O		
Heavy Stems		4 ▼	5 O			3 ▲	2 C	1 C		
Unthreshed Pods		1 ▲	2 C					3 C		
Trash		4 ▼	5 O		1 ▲	3 C	2 C			
<b>ROTOR LOSSES</b>	1	2 ▼	3 C	4 R	5 R					
<b>EXCESSIVE POWER CONSUMPTION</b>		1 ▲	2 O	3 F				4 R	3	
<b>GRAIN BLOWING OVER CHAFFER</b>					1 ▼	2 O				3
<b>BEAN LOSS OVER CHAFFER</b>		3 ▼		4 A	1 ▲	2 O				5
<b>SHOE SIEVE OVERLOADING</b>		4 ▼			3 ▲	1 C	2 O			5

**KEY**  
 O = Open  
 C = Close  
 A = Add  
 R = Remove/Rearward  
 F = Forward  
 ▲ = Increase  
 ▼ = Decrease

## Sunflower

HARVEST CONDITION	ADJUSTMENT									
	Inspect Concave for Plugging	Adjust Rotor Speed	Adjust Concave	Adjust Cage Vanes	Concave Wires	Adjust Fan Speed	Adjust Chaffer	Adjust Shoe	Grate Channels	Travel Speed
<b>CLEAN GRAIN SAMPLE</b>										
Damaged Grain		4 ▼	1 O			3 C	2 O			
Excessive Stems / Trash		5 ▼	4 O		3 ▲	2 C	1 C			
<b>ROTOR LOSSES</b>	1	4 ▲	2 C				3 O			
Unthreshed Heads	1	2 ▲	1 C							
<b>EXCESSIVE POWER CONSUMPTION</b>		1 ▲								
<b>GRAIN LOSS OVER CHAFFER</b>		5 ▼	4 O	3 *	1 ▲	2 O		5 **		
<b>GRAIN BLOWING OVER CHAFFER</b>					1 ▼	2 O				
<b>SHOE SIEVE OVERLOADING</b>				3 *	2 C	1 O	4 **††			

**KEY**  
 O = Open  
 C = Close  
 A = Add  
 R = Remove/Rearward  
 F = Forward  
 ▲ = Increase  
 ▼ = Decrease

\*Change the concave configuration to more small wire concaves.

\*\*Cover the last two grates or use solid grate sections.

††Add extra helical kickers to enhance material flow.

Note: Install shoe bottom pan.

# TROUBLESHOOTING

## Wheat

HARVEST CONDITION	ADJUSTMENT									
	Inspect Concave for Plunging	Adjust Rotor Speed	Adjust Concave	Adjust Cage Vanes	Concave Wires	Adjust Fan Speed	Adjust Chaffer	Adjust Shoe	Grate Channels	Travel Speed
<b>CLEAN GRAIN SAMPLE</b>										
Damaged Grain	3	1 ▼	4 O					2 O		
Heavy Stems		4 ▼	5 O			3 ▲	2 C	1 C		
Unthreshed Heads		1 ▲	2 C					3 C		
Fines		4 ▼	5 O			1 ▲	3 C	2 C		
<b>ROTOR LOSSES</b>	1	2 ▼	3 C	4 R						
<b>EXCESSIVE POWER CONSUMPTION</b>		1 ▲	2 O							3
<b>GRAIN LOSS OVER CHAFFER</b>						1 ▼	2 O			3
<b>GRAIN BLOWING OVER CHAFFER</b>		3 ▼				1 ▲	2 O		4 A	5
<b>SHOE SIEVE OVERLOADING</b>		4 ▼				3 ▲	1 C	2 O		5

**KEY**  
 O = Open  
 C = Close  
 A = Add  
 R = Remove/Rearward  
 F = Forward  
 ▲ = Increase  
 ▼ = Decrease

# TROUBLESHOOTING

## Increasing the Efficiency of Axial-Flow Combines in Tough Harvest Conditions

These suggestions have helped many combine operators increase their efficiency in challenging conditions:

- If congestion becomes a problem in green, weedy crop conditions, reduce the rotor-to-concave clearance and/or increase the rotor RPM to help the green material move through the rotor cage. This applies to all Standard, Specialty, and AFX rotors.
- Some operators have improved the movement of green material through a standard rotor with minimum grain loss by installing notched separator bars on the rotor over the separator grate area
- When harvesting hard-to-thresh grains with any rotor, help the combine complete the threshing operation by retarding two or more of the transport vanes to the slow position over the concaves, beginning with the first two vanes. For very severe hard-to-thresh conditions, such as a heat-stressed crop, interrupter bars can be installed in the concaves.
- In most cases, however, once the desired concave clearance is set, the best way to achieve ideal operation is to vary rotor speeds. Another plus for the AXIAL-FLOW concept.

### Optimizing Straw Quality

The grain-on-grain and rubbing nature of the Axial-Flow combine threshing and separating system can inherently reduce straw length, making baling straw challenging in some conditions. Some specific settings and harvesting conditions can be implemented to help produce longer length and quality straw. Special settings tend to reduce threshing and separating performance, so a balance of straw value and grain loss must be determined when making adjustments.

### Reduce aggressiveness of rotor and move material through the rotor cage quickly:

- Standard rotor—remove the first two sets of straight rasp bars if threshing is not impaired. Use smooth (not notched) separator bars.

- Specialty rotors—remove the straight separator bars and replace them with rasp bars. Do not use spiked rasp bars unless necessary due to trashy conditions.
- Reduce rotor speed and open the concave, but maintain threshing and separating performance
- Adjust transport vanes over separator grates to the fast position
- Adjust transport vanes over the concave area to the mid or fast position

### Configure rotor cage for smoother material flow:

- Use small wire concaves, or at a minimum, in the first concave position
- Use slotted grates with bars on the outside in the 1/2 hole position
- If grain loss is not an issue, use solid separator grates in the second and third positions

### Other machine settings:

- Use a combine with discharge beater instead of straw chopper
- Lower chopper/beater pan to the “Corn” position
- Retract the straw chopper concave and/or reduce chopper/beater speed
- Reduce rock trap beater speed
- Remove straw spreaders
- If straw is being driven into the stubble, leave spreader discs in place, but remove spreader bats or angles

### Harvesting conditions:

- Harvest when straw is tough, usually during damp conditions such as early morning or late evening
- Cut stubble lower for longer stems

## Increase Productivity with the Case IH AFX Rotor

With over 25 years of experience in rotary technology, Case IH stands tall with the most advanced design in rotary technology on the market today. The AFX rotor is now available as a Service retrofit for all 40, 60 and 80 size Axial-Flow combines. Benefits of the AFX rotor include:

- Increases throughput by as much as 25% in tough crops or harvesting conditions
- Allows harvesting earlier in the day, and later at night. Adds hours to the day when tough conditions stop most combines.
- A smoother, uninterrupted crop flow means more consistent delivery to the cleaning system
- Reduces peak horsepower demands in tough conditions, reducing load on the rotor drive belt
- Creates a powerful vacuum to move dust away from the feeder house and cab for better visibility to the header
- Results in quieter operation
- Improves fuel efficiency

The position of the standard eight straight separator bars are for a corn combine equipped with the AFX rotor (see figure 23.1).

The position of the four straight separator bars in a combine equipped for use in small grains with the AFX rotor (see figure 23.2).

A unique feature about straight separator bars is removal isn't required to harvest other crops – a great time saver. These separation bars control material flow for effective separation. However, they are not recommended for rice.

- Use six bars on 2144 and 2166, and eight bars for the 1680, 1688, 2188, and 2388 to harvest corn
- On grain machines, the separator bars are installed from the factory. The 1640, 1644, 1660, 1666, 2144, 2344, and 2366 have three bars in-a-row over the first grate and the 1680, 1688, 2188, and 2388 have four bars mounted in a staggered pattern over the first and second grates.

Refer to the Operator's Manual for correct placement of helical kickers (see figures 23.3 and 23.4).

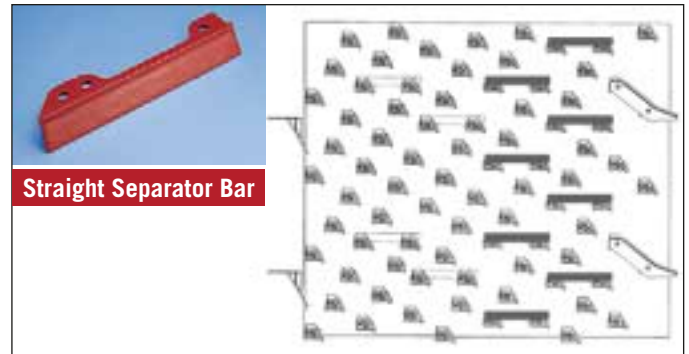

Figure 23.1

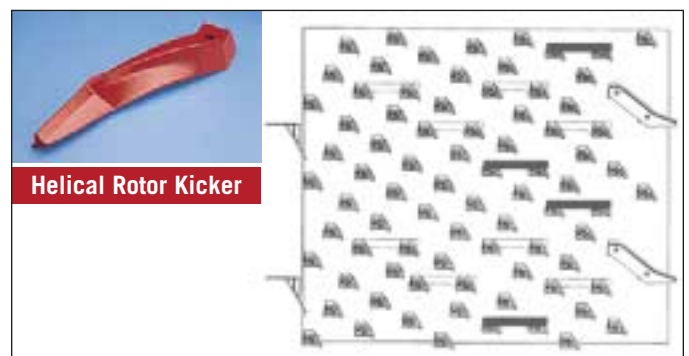
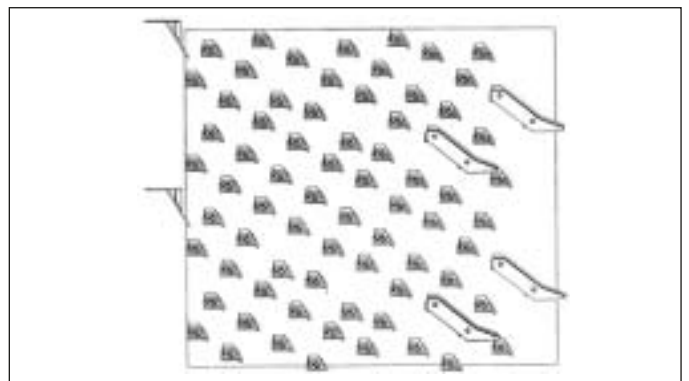
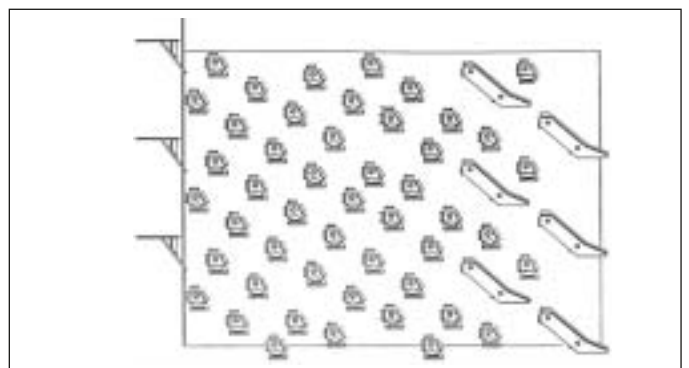

Figure 23.2



Suggest placement of helical kickers for sunflower on the 30" Specialty Rotor on the 1680, 1688, 2188, and 2388 combines.

Figure 23.3



Suggested placement of helical kickers for sunflower on the 24" Specialty Rotor on the 1640, 1644, 1660, 1666, 2144, 2166, 2344, and 2366 combines.

Figure 23.4

# TROUBLESHOOTING

## Increase Productivity with the Case IH AFX Rotor (cont.)

In summary, the rice and Specialty rotors are well suited for high-yielding crops.

- They have been very successful in harvesting crops like rice, weedy wheat and barley, milo, high-moisture corn, edible beans, alfalfa, blue grass, safflower, and sunflower
- Crops that can be harvested well with either the standard rotor or Specialty rotor include barley, wheat, commercial grade corn, rye grass, and sunflowers

Some additional optional threshing and separating components are available to address specific crop conditions.

- Interrupter bars are used to increase threshing aggressiveness in hard-threshing small grains. The effect of Interrupter bars is to increase threshing area with additional concave bars (see figure 24.1).
- Spiked rasp bars increase agitation of the crop mat as it moves through the rotor cage. Spiked rasp bars will provide additional separation in heavy straw and crop residue conditions (see figure 24.2).
- In addition, smooth rasp bars are now available for the Standard, Specialty and AFX rotors (see figure 24.3). Smooth rasp bars are recommended for use in food grade crops such as food corn where minimal crop damage is a requirement. Dealers can find more information in Service Bulletin NHE SB 001 92.

## Evaluating Grain Loss and Combine Performance

It's Harvest-time, and the return on a season's investment in labor, land, fertilizer, herbicide, and pesticides all lies with the combine's ability to put every kernel in the grain tank. A tall order, and in reality impossible. But the Axial-Flow Combines from Case IH will get you closer to perfection than any other combine.

Some simple steps should be taken as the combine is adjusted to match each crop and season, to check the cutting, threshing and separating performance of the combine, and isolate where adjustment may be necessary to get the best possible sample in the tank, with minimal loss.

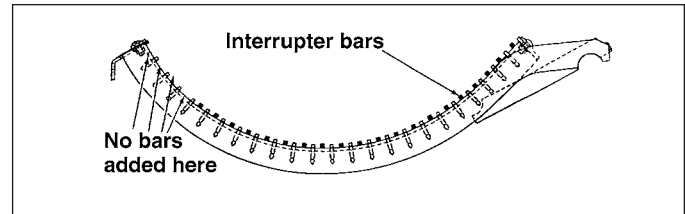

Interrupter bars on 1992 and after.  
(Not recommended for AFX Rotors).

Figure 24.1



Chrome Alloy Spiked Rasp Bar

Figure 24.2



Smooth Rasp Bar

Figure 24.3



# TROUBLESHOOTING

## Evaluating Grain Loss and Combine Performance (cont.)

A structured method of determining the source of loss is essential prior to making any adjustment to reduce loss. The illustration demonstrates how to make an accurate assessment of the source of harvest loss.

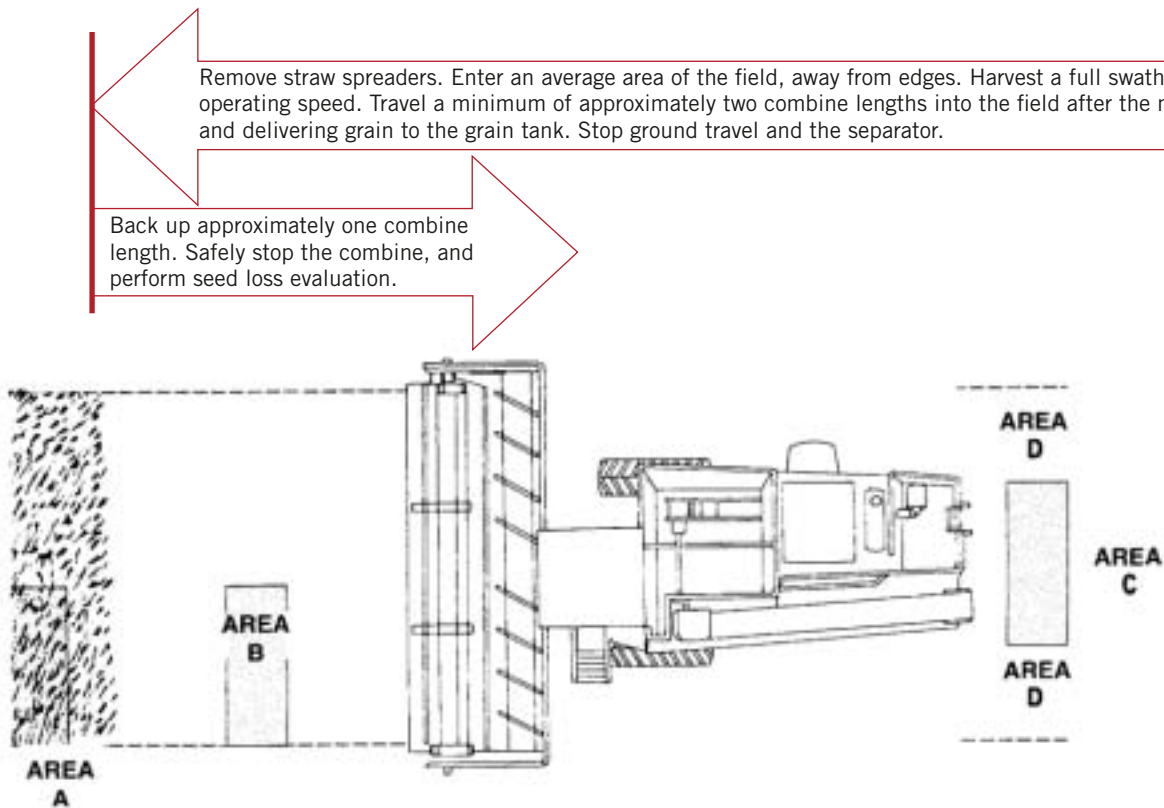

The number of seeds counted in each area indicated represents loss in various stages of harvest:

**Area A:** Pre-harvest loss in standing crop, prior to contact with the reel.

**Area B:** Pre-harvest + Header loss. (Header loss = B – A) Loss occurring at the header due to shatter, dropped heads.

**Area C:** Pre-harvest + Header + Separator Loss. (Separator loss = C – B – A) Separator loss will not be isolated to the rotor or cleaning system.

### Isolating Separator Loss

Separator loss can be isolated to rotor or cleaning system loss in either of two ways.

1. Note the current chaffer and sieve settings. Open shoe and chaffer sieves fully, and repeat the test as illustrated. If observed separator loss is unchanged, loss is coming from the rotor. If loss decreases, observed loss from first test was from the cleaning system.
2. Perform the initial test with straw spreaders installed. Make sure the separator has stopped before backing away from cut crop. Observed loss in Area “C” is from the sieves (cleaning system). Observed loss in Area “D” is rotor loss that was spread across the width of the machine by the straw spreaders.

### Determine the Amount of Loss at Each Source

The next step is to count the grains lost on the ground in each “counting area.” Each “counting area” should be equal to about 10 square feet.

To convert the amount of loss you find at any point to bushels, refer to the seed loss tables in your Operator’s Manual. Losses should be checked in several areas and averaged to eliminate the effects of any uneven feeding.

### Make the Proper Adjustments

Once the loss counts have been performed as described, required areas of attention will be identified.

- To reduce header losses, make sure header is adjusted properly as explained in the

### Operator’s Manual

- Before making adjustments for separator losses, be sure there are no grain leaks due to missing bolts, open clean out doors, or other obvious causes
- For adjustments to the rotor and cleaning system, see your Operator’s Manual. For additional separator adjustments and recommendations, see tables on pages 17 through 21.

# TROUBLESHOOTING/UPDATES AND KITS

## “Power-Stall” Problem Diagnosis (Quick Stop)

Problems with internal components are difficult to analyze. If you’re losing grain at the separator, you may want to use the “power-stall” diagnostic method.

- The “power-stall” uses an approved method of stopping the separator quickly while harvesting
- By preventing the separator from emptying, as would be the case in a normal shutdown, this procedure allows inspection of the inside of the combine as if it were in operation (see figure 26.1)
- There will be some major differences between the conditions observed and those that exist during operation. Even with these obvious limitations, the procedure can be an extremely useful diagnostic “tool.”
- See the Operator’s Manual under the heading “Quick Stop” problem Diagnosis for a description of the procedure

## Additional Combine Performance and Reliability Residue Management

Larger combines, bigger headers, and higher yielding crops means a high volume of material is flowing from the back of your combine. The need to distribute residue evenly is crucial. Uneven soil drying and warming, and excess residue cover can restrict the emergence of the next crop.

- Curved straw and chaff spreader bats “throw” residue further from the center of the spreader, allowing for wider coverage (see figure 26.2)
- Bats can be set in three different positions to vary distribution depending on the crop and field conditions
- Curved bats can be installed on earlier models of Axial-Flow combines, as well as later combines that were not shipped with them as a factory-installed option

An externally adjustable straw chopper that became standard equipment on 2001 model machines can also be retrofitted to earlier models of Axial-Flow combines (see figure 26.3).

- Longer knives improve crop material cutting
- Spreader kits include two pulley diameters (8" and 10") mounted on the same hub that allow a quick change of speeds for the spreader, based on crop and residue conditions and header height

See your Case IH dealer for curved bat or adjustable straw chopper retrofit kits.



Figure 26.1



Figure 26.2



External Straw Chopper Adjuster Kit Part No. B95783 **Figure 26.3**  
- complete chopper kit w/bolted knives 80 size Part No. B95784 - complete chopper kit w/bolted knives 40/60 size

# UPDATES AND KITS

## Unloading Auger Support Band and Strap

A revised unloading tube strap assembly has been released for 208" unloading augers for 2366, 2377, and 2388 combines (see figure 27.1).

- The new band provides additional strength at the transport saddle area of the tube; this supports the weight of the auger when grain remains in the tube while the auger is in the transport position.
- Case IH dealers can provide additional information, and can reference Service Bulletin NHE SB 028 05



Figure 27.1

## Poor Grain Tank Sample or Excessive Losses in High Volume/Moisture Crops

For 2100 and 2300 series combines that are equipped with the slower cleaning system speed, it may be too slow for these crop conditions. A speed-up pulley is released for production and service.

## Unloading System Shear Bolts

Do not substitute unknown bolts for the unloading system shear bolts. Incorrect bolts can cause extensive damage to the system.

## Field Tracker Field Operation in Automatic Mode

A Service Bulletin has been released with information to aid in a better understanding and operation of the field tracker in the automatic mode while using a 1020 header or 1000 series corn head. For more information, contact your Case IH dealer.

## Bring Your AXIAL-FLOW Combine Up-to-Date for Increased Productivity and Profitability

Many improvements have been made in Case IH combines over the years. You'll want to check with your Case IH dealer to see which of the following optional equipment or improvements can be incorporated in your combine to help you harvest your crops more efficiently.

- Heavy-duty Lower Feeder Jackshaft
- Cross Flow™ Fan Package Retrofit
- Shaker System Slip Clutch Drive Hub
- Extended Life Augers
- Spreading Width Options
- High-Wear Rasp Bars for Specialty Rotors
- External Straw Chopper Adapter Kit
- External Sieve Adjustment Kit
- AFX Rotor and Recommended Product Support Kits
- Fifty-two (52) Hole Configuration Cones
- Cone Kits for 52 Hole Cones
- Larger Rotor Drive Pulley Kit for 2388 Combines
- Poly Hoods, Divider Kits, and Completing Kits

## Bring Your Older Corn Head Up-to-Date

Case IH engineers spend every harvesting season in the field searching for ways to improve AXIAL-FLOW combines and corn heads. Your local Case IH dealer can assist you with optional equipment and improvements will help make your machine operate more efficiently.

- Stalk Roll Spiral Assemblies
- Field Tracker Drive Shaft and Bearing Support
- Lower Stalk Roll Bearing Shield
- Auger Trough Material Thickness
- Stalk Roll Weed Knives
- Gatherer Rear and Side Extensions
- Auger Slip Clutch
- Stalk Roll Lower Bearings (see figure 27.2)



Figure 27.2

# UPDATES AND KITS/AFS

## Bring Your Older Grain Header Up-to-Date (cont.)

Case IH is continually improving all their agricultural equipment. Check with your Case IH dealer to see what optional equipment or improvements will help make your machine operate more efficiently.

- Diamond Sta-Sharp™ and Super Sta-Sharp™

## Knife Sections

- Cutter Bar Rebuild Kits for 1-1/2" and 3" knife systems
- Auger Stripper Extensions
- 3" Double Heat-Treated Guard

## Runners and Skid Shoe Improvements for:

- 1020 Headers
- AHHC (Auto Header Height Control) Cable Replacement Linkage
- Knife Back Reinforcing Kit
- Bottom Skid for 1010 Headers
- Deflector Fingers–1020 header end divider
- New cutter bar poly–1052, 2052, and 2062 headers

## AFS

There are two kinds of power that enhance productivity in today's agriculture—the power you find in new, modern equipment, and the power of information you harness with Case IH AFS Precision Farming systems (see figure 28.1).

Five basic components work together to capture harvest information as the combine moves through the field.

- The flow sensor measures grain volume
- The moisture sensor measures the grain moisture and temperature
- A ground speed sensor and programmed header width determine coverage area
- The yield monitor combines all crop and area data to populate the touch screen display with instantaneous and historical yield information in terms of dry bushels per acre
- Information is stored on a memory card that transfers data to desktop software, helping you manage your farming operation, using the outcome of your past year's crop in future cropping plans
- Add a DGPS receiver and record a data point every 1, 2, or 3 seconds as you travel through the field, to fully realize the power of information

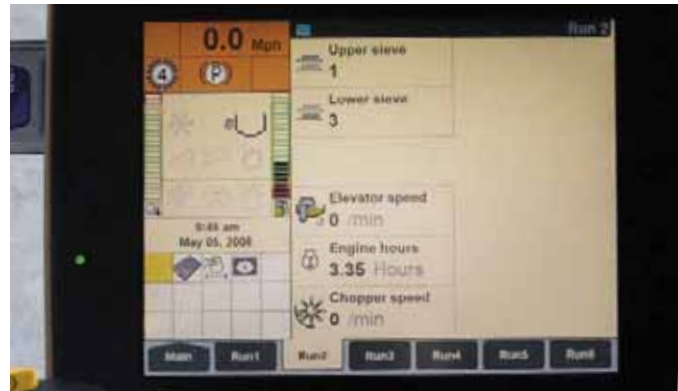

Figure 28.1

Since the dawn of time, and man's first tools, one thing remains the same—if not used correctly, a tool's full potential is seldom realized. With that thought in mind, some simple guidelines may help you make AFS operation simple and second nature, meeting the full potential you expect from your investment.

Some simple adjustments and maintenance, as well as conscientious component calibration, are necessary to assure accuracy.

To understand the need for system calibration, consider that AFS operates using electronic components that translate ground speed, header position, grain moisture, and grain volume data into electrical signals.

- Many variables would make “set-at-the-factory” accuracy impossible, the operator must calibrate the system once in the field, using scales and moisture testers with known accuracy to verify the weight and moisture of the grain
- The operator manually enters the actual numbers, and the AFS system makes adjustments so future harvest data, as well as the calibration load and prior harvest data, accurately reflects the moisture and weight of the grain being harvested

### System inputs that require calibration:

- Header stop height (turns counting on and off)
- Distance (used to calculate ground speed)
- Grain Temperature
- Grain Moisture
- Grain Weight

## Grain Moisture and Weight Calibration

The most common calibration necessary is crop calibration—moisture and weight. Prior to harvesting, some mechanical checks should be performed. The flow sensor impact plate should be inspected. If any holes are worn through the plate it should be replaced.

The distance between the clean grain elevator deflector plate in the elevator head and elevator paddles is critical to assure all grain contacts the flow sensor impact plate.

- The elevator head shaft is adjusted vertically to achieve a 3/8" to 1/2" paddle tip to deflector plate clearance (see figure 29.1)

After this adjustment is set, all elevator chain tension adjustments must be made at the lower elevator shaft.

- Record the sensor calibration number from the decal on the top of the elevator. This number is entered in the touch screen display during combine "Vehicle Setup" (see figure 29.2).

The grain moisture sensor operates on the principle of an electrical current flowing from the sensor fin, through the grain, and to the ground (see figure 29.3).

- The grain moisture sensor fin and temperature sensor must be clean for proper function. A buildup of crop sap can reduce sensor accuracy.
- Remove any crop residue by scraping or using soap and water or solvent to clean the moisture fin and temperature sensors

The bypass auger is controlled by a proximity switch that cycles the auger as required, to assure the sensor fin is always in contact with grain.

- The bypass auger should be removed and cleaned. Ensure that the auger has not seized to the plastic block that supports the non-drive end (see figure 29.4).

Operators should monitor Instantaneous Moisture values while harvesting to confirm the sensor is functioning. If moisture values do not show some fluctuation, a problem may exist with the moisture sensor that requires attention to assure accurate harvest data.



Figure 29.1



Figure 29.2



Figure 29.3



Figure 29.4

## Grain Moisture and Weight Calibration (cont.)

- If moisture readings are consistently very low, the auger may be operating constantly, preventing grain contact with the fin. (Likely to occur only in lower yield crop where the bypass auger removes grain from the bypass as quickly as it enters).
- Your Case IH dealer should be consulted to correct the condition
- If moisture readings are consistent, but at a value more likely to be representative of actual grain moisture content, the auger may not be operating
- The sensor is merely providing a moisture reading of a static sample that is in the bypass housing

The bypass auger is controlled by a proximity switch that cycles the auger as required, to assure the sensor fin is always in contact with grain.

- The auger should operate for 30 seconds after the separator is disengaged, to clean grain from the bypass. Auger operation can be checked by visually watching the end of the auger shaft during this 30 second period, to see if the shaft is turning.
- If not, check to assure the moisture sensor bypass auger use is not blown. If the fuse is not at fault, contact your Case IH dealer for assistance.

Operators must also remember that adjustment or replacement of any component that affects calibration requires re-calibration.

- Memory management features of AFS allows operators to apply calibration values to specific loads, or beginning at a specific time during harvest, such as the time when component replacement occurred.
- Refer to the Operator’s Manual after re-calibration to use the correct Utility menu to apply calibration to the correct harvest data.

To record harvest data, four criteria must be met.

- A memory card must be inserted in the top slot of the display before turning the power ON. The card should have only ONE \*.yld file or ONE \*.cnh folder. Use Windows Explorer to confirm.
- The clean grain elevator must be running between 250 and 599 RPM
- Ground speed must be registered
- The header must be lowered below the header cut “stop height” position

When data is being recorded, the “REC” indicator on the display will be darkened.

In understanding the calibration process, the operator realizes the importance of maintaining an accurate record of the calibration load weight and moisture test results, as well as load identification.

- Identification is necessary to enter a load name into AFS, as well as on scale tickets. The operator should anticipate the need for load names, and can actually enter load names prior to harvest. **See the calibration record table included in the AFS Operator’s Manual or (see table 30.1).**

Crop Type:				Date:		
Combine:				Operator		
Field	Load	Flow Bu/Hr	Estimated Weight	Actual Weight	% Error	Include? (Y/N)
1	Cal 1 Hi					
2	Cal 2 Hi					
3	Cal 1 Med					
4	Cal 2 Med					
5	Cal 1 Lo					
6	Cal 2 Lo					
7						

Table 30.1

## Grain Moisture and Weight Calibration (cont.)

Do not attempt to make the first load harvested a calibration load.

- Frequent stops and starts (as harvest begins) to adjust the machine will result in inaccurate calibration. Once calibration is performed, calibration values can be applied to the initial loads harvested prior to calibration.
- Do not harvest calibration loads until headlands are harvested
- Prior to harvesting the calibration load, make sure the grain tank and truck, cart or trailer used to transport the calibration load is completely empty. Attempt to harvest calibration loads of nearly the same size for best accuracy. Loads of at least 10,000 lbs. are suggested.
- Be sure to select a new load prior to harvesting any of the crop to be used for calibration
- Empty the load into the truck or trailer. Immediately select a new load after unloading. Failure to change loads will add to the original calibration load and lead to high calibration errors.
- Do not unload on-the-go when harvesting calibration loads

More than one calibration load is suggested, using a range of speeds and throughputs that are expected in normal operation. Harvest at least 4 calibration loads for each crop (6-8 is recommended).

- The objective is to “teach” the flow sensor what different flow rates “feel” to the sensor
- The high output rate should be near that which the operator would prefer to operate the machine
- Medium and low rates are also suggested since variations in yield throughout the field, or conditions that result in reduced ground speed, can periodically lower throughput during normal harvest
- A medium flow rate is 30% less than the high flow rate. A low flow rate is 30% less than the medium flow rate.  
**Example:** If the maximum observed flow – instant dry bu. is 2,000 bu./hr. on the display this is considered the high flow rate. The medium flow rate would be 1400 bu./hr. and the low flow rate would be 800 bu./hr. Reduced flow rates are achieved by driving slower or taking a reduced swath.
- The operator should attempt to maintain a consistent flow rate when harvesting each of the loads. Use the “Instantaneous Flow-Dry” display to monitor throughput.
- Take 4-5 moisture tests in each load. Use the average value as the “Actual” moisture reading.

An understanding of these basics is essential in achieving accurate AFS data records. The AFS Universal Display Plus Operator’s Manual for Harvesting Operations provides step-by-step and detailed instructions for performing AFS operations, calibrations, and managing the display information and harvest data (see table 31.1).

- Follow instructions to “Apply Cal Values” as necessary to loads harvested prior to calibration

## BASIC START-UP REQUIREMENTS

### STEPS FOR A SUCCESSFUL HARVEST

The following are the basic steps required to start harvesting:

**NOTE:** Ensure ATA Flash Data Card is installed prior to powering the system and performing any set up functions.

- Check time, date, and units of measure. (MAIN Screen> SETUP Screen>Display Screen)
- Select correct machine model, 44/66 or 77/88. (MAIN Screen>SETUP Screen>COMBINE Screen>Vehicle Setup ▼)
- Enter grain flow sensor calibration number. (MAIN Screen>SETUP Screen>COMBINE Screen>Vehicle Setup ▼)
- Set up farms, fields, and loads. (MAIN Screen>HARV Screen>{as determined by user defined screens})
- Check that proper crop type is assigned before harvesting a given farm field, load. (MAIN Screen>HARV Screen>{as determined by user defined screens})
- Check % Crop Trade Moisture and Crop Trade Weight (“USA” units) to be used as the dry basis for the crop being harvested. (MAIN Screen>SETUP Screen> COMBINE Screen>Crop Setup ▼)
- Associate header type and size with each crop type. (MAIN Screen>SETUP Screen>COMBINE Screen>Crop Setup ▼)
- Set Header Stop Height for each crop type. (MAIN Screen>SETUP Screen>COMBINE Screen>Crop Setup ▼)
- Set Header Alarm Beep to 1, 2, 3, 4, or 5 Beep. (MAIN Screen>SETUP Screen>COMBINE Screen> Vehicle Setup ▼)
- Set GPS configuration and logging interval (if equipped). (MAIN Screen>SETUP Screen>COMBINE Screen> Vehicle Setup ▼)
- Perform Distance Calibration (MAIN Screen> CAL Screen> DISTANCE Screen)
- Harvest a sample of the grain.
- Calibrate moisture sensor. (MAIN Screen>CAL Screen> LOAD Screen>MOISTURE ▼)
- Harvest calibration loads at different throughput levels and then perform full calibration. (MAIN Screen> CAL Screen>AREA and LOAD Screens)
- Calibrate yield sensor. (MAIN Screen>CAL Screen>LOAD Screen>YIELD ▼)
- Repeat calibration process for each crop type.

Table 31.1

## Firmware and Software Versions

The Display Monitor can be used in several AFS applications, all capable of using and recording data used in AFS Desktop Software. Firmware is what makes the Display Monitor “become a combine” and display the data necessary for harvesting operations. Display Firmware and AFS Desktop Software must be compatible. The following table defines component compatibility for past and present configurations.

Machine Series	GPS Connection	Display Firmware	YMIU	Receiver Firmware	Datacard Size & Type (Min–Max)	Desktop Software (Min–Rec)
1600 2100 2300	RS-232	6.02B-C	N/A	1.11–CURRENT	256KB–4MB SRAM	Any–CURRENT
		<3.2	1.25, 2.2	1.11–CURRENT	4MB–16MB ATA	AFS2000 2nd Edition–CURRENT
		4.*	2.2	1.11–CURRENT	4MB–1GB ATA, CF ①	AFS 3.0–CURRENT
		31.* Universal Display Plus (2-slot)	2.2	1.11–CURRENT	4MB–1GB ATA, CF ①	AFS 5.0–CURRENT
		31.* ICDU2 (1 slot)	2.2	1.11–CURRENT	32MB–1GB ATA, CF ①	AFS 5.0–CURRENT

① Compact flash memory card.

Table 32.1

## Assisted Steering Options

Other Advanced Farming Systems features available for Case IH combines includes GPS controlled assisted steering.

- EZ-Steer uses a steering-column mounted electric motor to turn the steering wheel on command from a GPS guided controller (see figure 32.1)
- Autopilot integrates an electronic control valve with the standard steering valve, to steer the combine with GPS signals

If assisted steering is added to combines not currently equipped with GPS mapping capability, component integration allows use of the steering system GPS signals for AFS yield mapping. A special harness available from your Case IH dealer can be used to integrate the two systems (see figure 32.2).

As the technology of GPS and precision farming has progressed, hardware has changed as new capabilities have evolved.

Many system components are compatible with the use of specialized connectors or harnesses. Your Case IH dealer has the documentation necessary to help you match existing components with new hardware you may select to further the reach of the latest technology in your farming operation (see figure 32.3).



Figure 32.2



Figure 32.1



Figure 32.3



## Combine Storage

When harvest is done, make sure to give your combine some end-of-season and pre-storage attention before the shed doors close. Off-season neglect can cost big in terms of corrosive damage, rust, and deterioration—all avoidable with a little thought to prevention and maintenance. The combine should be stored in a dry, protected location. Outside storage, subject to weather and elements will shorten the life of the machine.

1. The combine should be thoroughly cleaned before storage to remove chaff and debris that can collect moisture or attract rodents during storage.
  - A high volume and velocity air blower like a leaf blower or industrial compressor works best when debris is dry
  - Washing the unit will provide the most complete cleaning, removing debris that may be stuck to grease or oily accumulations that cannot be removed with just compressed air or mechanical cleaning; as well as removing the grease and oil as well
  - If the unit is washed, care must be exercised to assure **COMPLETE** removal of chaff and debris, especially from inconspicuous areas where it will result in accelerated rust and corrosion over an extended period of time
  - Tightly cover the engine starter and alternator with plastic before washing the combine
  - Avoid directing the blast from a high pressure washer or steam cleaner against sealed bearings where moisture that infiltrates the seals will remain and lead to corrosive damage
  - In areas that freeze make sure to remove any water that maybe trapped in the transition cone, auger bed or grain tank. All of these areas have removable covers, doors, or plugs that allow water to drain.
2. After thoroughly cleaning the combine and allowing it to dry, lubricate the machine as specified in the “Lubrication/ Filters/Fluids section of the Operator’s Manual.”
  - Remove the coverings from the starter and alternator
3. Clean the inside of the machine including the concave and separator grate, chaffer and shoe sieves, cleaning fan, clean grain and tailings auger troughs.
  - Open the clean grain and tailings elevator doors
  - Open the auger bed front doors and clean the auger bed
4. Clean the inside of the cab and instrument panel. Clean the cab air and re-circulation filters.
5. Rodents can damage a combine while in storage. Rodents will eat plastic, insulation, or rubber materials, especially when coated with grain dust.
  - Clean the areas where rodents may nest

- Leave access panels and doors open to remove convenient nesting pockets. In some conditions, leaving mothballs will help discourage rats and mice.
6. Run the engine long enough to completely warm the oil in the crankcase before draining the oil.
    - Remove and replace the oil filter as instructed
    - Fill the crankcase with fresh oil and run the engine for two to five minutes
  7. Open the drain on the water separator fuel filter and drain water and sediment.
    - Fill the fuel tank with a premium grade diesel fuel

If this fuel grade has not been used regularly, drain the fuel tank and fill with premium diesel fuel. **Do not store the combine with bio-diesel fuel in the tank or fuel system.**

- Run the engine for five minutes to circulate the fuel through the fuel injection system
  - Close the fuel shutoff valve between the water separator filter and fuel tank to prevent fuel draining from fuel injection system into the fuel tank
8. Clean the air cleaner filter and body.
  9. Check coolant anti-freeze protection. Use only low silicate, heavy-duty coolant in the cooling system.
    - Add cooling system conditioner and change the coolant filter conditioner
  10. Cover the engine breather pipe and exhaust pipe.
  11. Batteries can remain in the combine, but must be fully charged to prevent freezing in cold temperatures.
    - Remove the battery ground cables to prevent slow discharge
  12. Store the combine out of direct sunlight. Clean tires before storage and support the combine on blocking if possible to remove load from the tires.
    - If the combine is not blocked, check tires frequently and maintain inflation during storage
  13. Lubricate chains with light oil or chain lubricant.
  14. Lower the head to remove load from the hydraulic system.
    - Retract all hydraulic cylinders if possible. Coat exposed cylinder rods with grease to prevent rust and corrosion (clean grease from rods when removing the combine from storage).
  15. Remove tension from belts.
  16. On combines equipped with Moisture Sensor, remove the bypass auger and remove grain from the housing. Make sure the auger turns freely in the plastic bearing block.

## Removing the Combine from Storage

Consult the Operator’s Manual. In addition to confirming fluid levels and closing cleanout doors, several other inspections are suggested when preparing the combine for use.

# NEW COMBINE PRODUCT SUPPORT KITS

## Heavy-duty Rotor Drive Gear Box Kit

- For 2388 model year 2003-2005
- Kit includes heavy-duty gear box, mounting brackets, new style rotor drive belt, and hardware
- Wider and larger diameter gears for increased strength and durability
- Increased reliability



Part No. 87397334

## Power-Clean™ Evacuation System

Two new kits are now available to substantially reduce the cleaning requirements of the rotary air screen (RAS), radiators, coolers, and engine air cleaners.

### Rotary Air Screen Metal Conversion and Vacuum Kit

- Minimizes the chances of the RAS plugging from crop debris (corn leaf, corn sucrose mist, and fine/sticky dust)
- Reduces the cleaning requirements of the RAS, radiator, coolers, and engine air cleaner
- Kit includes metal RAS, hydraulic driven vacuum components, hoses, mounting brackets, outlet ducts for debris, mounting hardware, and instruction manual



Part No. 87362263  
Metal Rotary Air Screen

### Spring Loaded Rotary Air Brush Kit

- Cleans the interior of the RAS to dislodge any debris stuck to the rotary air screen
- Reduces the cleaning requirements of the RAS, radiator, coolers, and engine air cleaner
- Kit includes rotary air brush assembly, stationary brush, mounting hardware, and instruction manual



Part No. 87382753  
Rotary Brush

Part No. 87362263 RAS Metal Conversion and Vacuum Kit for 2377 and 2388 Combines

Part No. 87382753 Rotary Brush Kit for 2377 and 2388 Combines

## Sieve Kit

- Original equipment sieves
- Kit includes sieve with installed rubber flaps, seals, wire harness, and grain loss sensor with brackets
- Complete – ready to install
- Application – 1680 with long sieves and later
- Selection – 80 size combines



- Part No. 1347372C7E – Chaffer – Petersen
- Part No. 1322467C6E – Chaffer – 1-1/8" Grain
- Part No. 1322659C6E – Chaffer – 1-5/8" Corn
- Part No. 1322673C6E – Chaffer – 1-5/8" Closz slat
- Part No. 1979328C8E – Shoe – 1-5/8" Corn
- Part No. 1322464C7E – Shoe – 1-1/8" Grain

# NEW COMBINE PRODUCT SUPPORT KITS



**Part No. 87535919**

- This kit mounts to the left side of the feeder and has cables that connect to a pair of engagement pins that latch the header to the combine
- Combine kit includes cables, handle guards, springs, hardware, and I-sheet
- Header kits include engagement pins and mounting hardware
- These kits are designed to make it easier to attach various Case IH headers to Case IH Combines

## Grain Tank Unloading Speed-up Kit

- Faster unloading speeds for mid-range combines
- Kit includes sprockets, chain assemblies, mounting supports, bearings, and hardware
- Drive chains increased one size to improve load capacity and chain life
- Kit is designed to increase unloading rates from 1.9 Bu/sec to 2.4 Bu/sec like the new 2577/2588 combines



**Part No. 87539791 - Combines with field tracker (shown)**  
**Part No. 87539793 - Combines without field tracker**



**Part No. 87336803 - 1010/1020 Header (shown)**  
**Part No. 87337673 - 2200/2400 Corn Head**  
**Part No. 87352570 - 1015 Pick-up Header**  
**Part No. 87352569 - 1000 Corn Heads**  
**Part No. 87368703 - 2015 Pick-up Header**



**Part No. 87298938**

## Round Bar Concave Kit

- Kit consists of one 87456655 - Position 1 (shown) and two 412396A1 - Position 2 and 3
- One piece high strength design
- The round bars function to prevent silks or husks from hair pinning on the bars/wires in high moisture corn
- Concaves also have large wires that run 90 degrees to the round bars for soybean harvesting



**Part No. 87561634**

## Stainless Steel Auger Trough Wear Liner Kit

- Kit includes two stainless steel grain tank auger liners and 70 stainless steel pop rivets
- Restore life to a worn tank bottom or protect new tanks from wear. The liners slip under the grain tank cross augers. Drill holes and pop rivets in place.
- For all mid-range Axial-Flow® Combines

# NEW COMBINE PRODUCT SUPPORT KITS



Part No. 87571553

## Feeder Reverser Accumulator Kit

- Kit is designed to absorb system pressure spikes and prevent damage to the cylinder and/or valve
- Kit consists of an accumulator, mounting bracket, hydraulic fittings, and hardware
- For any mid-range Axial-Flow Combine with a factory installed feeder reverser or older machine updated with a feeder reverser kit



Part No. 87553948

## Rear Curtain Kit

- Kit consists of two rear curtains and special mounting hardware
- Spreader curtains are longer and positively connected to each other to form a defined curtain area for improved discharge of material and to prevent residue from accumulating on the rear axle and steering cylinder

Application: 2100-2500 Service Axial-Flow Combine



Part No. 87298935

## Externally Mounted Alternator Screen Kit

- Kit consists of rubber elbow, pipe connector, screen, and clamps
- Kit is designed to restrict dust flow into the alternator - promoting longer alternator life

Application: 1644, 1666, 1688-2588



Part No. 87528035E

## Stainless Steel Repair Kit

- Kit includes stainless steel repair patches, hardware, and I-sheets
- Kit is designed to extend the service life of corn head poly hoods

Application: 2200/2400 Series Corn Heads

Part No. 87528030E - Outer Row Kit

Part No. 87528033E - Inner Row Kit - requires two per inner hood

Part No. 87528034E - 6-Row Kit

Part No. 87528035E - 8-Row Kit (shown)

Part No. 87528036E - 12-Row Kit

# NEW COMBINE PRODUCT SUPPORT KITS



Part No. 87298864

## New Style Header Auger Finger Kits

- For 2006-2007, Model 2010 and 2020 Grain Headers
- Long wearing heat treated auger finger and hardware

Part No. 87298864 - complete set - 30' Header (shown)  
 Part No. 87298865 - complete set - 25' Header  
 Part No. 87298860 - complete set - 20' Header  
 Part No. 87298867C - two pack kit  
 Part No. 87298954C - deluxe finger kit

## EZ Latch Single Level Hydraulic Coupler Kit

- Kit includes coupler assembly, hydraulic lines, and hardware
- Kit is designed to make it easier to connect the hydraulics on the combine to the header
- Coupler for 1010/1020 Headers, 2200 Corn Heads, and mid-range Axial Flow Combines
- Combine these kits with the centralized header latch kit for even greater convenience



Connected Couplers

Part No. 87552504 - coupler half for 1000 Series Headers  
 Part No. 87301386E - coupler half for 1644, 1666, 1688, and later combines  
 Part No. 87662931E - coupler half for 2200 Corn Head

## Not New But Improved

- The material thickness on these elbows and vertical tubes have been increased by 30% for improved service life
- HVOF wear resistant coating included with Part No. B96190A—extended wear elbow
- The elbow grease ring groove has been modified to provide more uniform grease flow and improved service life

Grease lines and mounting hardware included but not shown.



Part No. B94090A - standard wear  
 Part No. B96190A - extend-a-wear  
 Heavy-duty Unloading Auger Elbow



Part No. B95650A  
 Heavy-Duty Vertical Tube

# AUTOMATIC LUBRICATION

## Why an Automated Lubrication System is Better

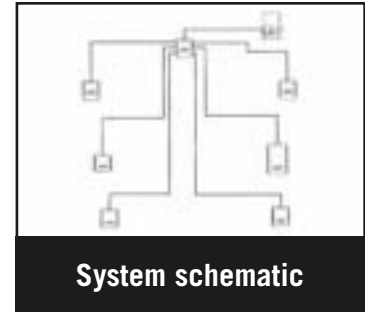

### Manual Lubrication

- Inconsistent lubrication
- Can't lubricate while running
- Potential contamination
- Premature pin, bushing, and bearing wear
- Labor expense/morning maintenance

VS.

### Automated Lubrication

- Constant lubrication (runs every 30 min.)
- Lubes while combine runs
- Closed system-no contamination
- Extended component life
- Less downtime

New Auto-lube System Kit is designed to service over 40 lubrication points on the combine. Kit available for 1020 header designed to service 13 lubrication points.

The system consists of a 12 VDC electric pump designed to pump Case IH 251H grease. It incorporates an easy accessible, adjustable timer and a clear, high impact polymer reservoir for visual indication of lubricant level.

The grease is proportioned by positive displacement metering valves that supply the proper amount of grease to each component. Each incorporates an indicator pin for confirmation of system operation. Kit includes all components and installation instructions.



### Kit Selection

PART NO.	DESCRIPTION	APPLICATION
B96372	AUTOMATED LUBRICATION SYSTEM	2100 & 2300 SERIES
B96374	AUTOMATED LUBRICATION SYSTEM	1020 HEADER
B96092	QUICK FILL GREASE GUN	CASE IH AUTOMATED LUBE SYSTEMS

### System Features and Benefits

- The auto-lube systems have been in use for 30 plus years, with use on off-road equipment since 1994. Currently available for Case IH Big Square Balers, Cotton Pickers, and Combines.
- Increases combine uptime - minimum of 1/2 hour productivity per day - by eliminating daily manual lube
- Significantly increases the life of components by lubricating automatically, once an hour, with small amounts of grease *while the machine is in operation!*
  - contaminants are purged and effective seals are created
  - fresh grease is maintained on all critical wear surfaces
- Reduces manual labor for daily lubrication and repairs
- Eliminates wasted grease resulting from manual lubrication

# ADJUSTMENT SLIDE RULE

## Combine Separator Adjustment Slide Rule

### How the Slide Rule works:

Identify the symptom you have, line up the slide rule with the symptom, and read the suggested adjustments in order of priority.

### Why:

To achieve maximum productivity from your Case IH combine.

### When:

The slide rule is a useful tool to make initial machine settings, and in-field adjustments to set the combine for maximum productivity.

Slide rules cover most common crops, and fit easily in the buddy seat compartment to be readily available when needed. It is easy to read, easy to follow, and gives step-by-step instruction to improve combine performance.



PM-12749  
Front

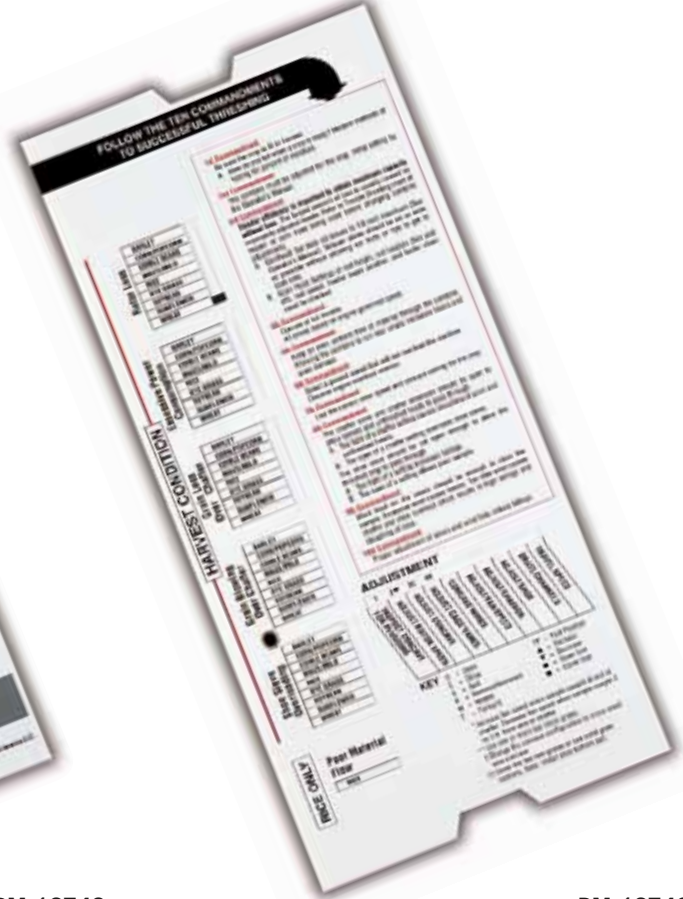

PM-12749  
Back



#### Now you can identify the Case IH parts you need online

- Visit [www.caseih.com/na](http://www.caseih.com/na)
- Click on Search for Parts under Parts & Service
- Enter your model number or product name
- View a parts list and diagram
- Build a list of the parts you need
- Contact your Case IH dealer to order parts



Safety Never Hurts!™ Always read the Operator's Manual before operating any equipment. Inspect equipment before using it, and be sure it is operating properly. Follow the product safety signs, and use any safety features provided.

Case IH and CNH Capital are registered trademarks of CNH America LLC. Any trademarks referred to herein, in association with goods and/or services of companies other than CNH America LLC, are the property of those respective companies.

CNH America LLC reserves the right to make improvements in design and changes in specifications at any time without notice and without incurring any obligation to install them on units previously sold. Specifications, descriptions and illustrative material herein are as accurate as known at time of publication, but are subject to change without notice.

This literature has been published for worldwide circulation. Availability of some models and equipment builds varies according to the country in which the equipment is used.

**CASE IH**